

Desoutter



Industrial TOOLS



NANO DRIVER **Electric Transducerized** **Screwdriver**

Extreme precision
Easy integration into automation
Integrated vacuum
On-screen programmable
Joint learning capability

More Than Productivity



Electric transducerised Very Low Torque - CVIXS



MAIN FUNCTIONS	
Programming modes	
Quick cycle	✓
Learning mode	✓
Number of cycles	50
Number of phases available	15
Phase characteristics	
Search sequence	✓
Run down speed	✓
Final speed phase	✓
Action on NOK	✓
Run reverse	✓
Jump to another phase	✓
Prevailing Torque	✓
Synchronisation phase	✓
Tightening strategies	
Torque	✓
Torque with angle monitoring	✓
Angle with torque monitoring	✓
Seating detection	✓
Stall torque	✓
Number of stored results	2000 to 10000 according configuration

Electric transducerised Very Low Torque - NANO DRIVER

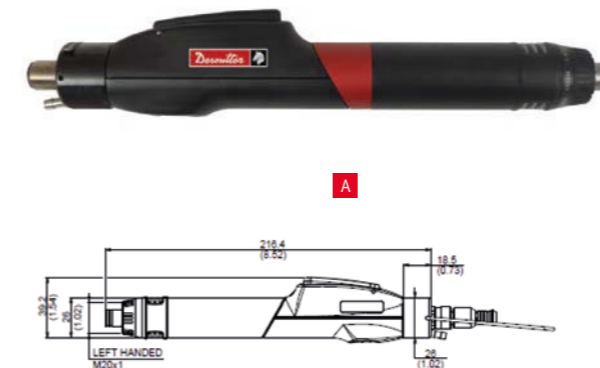

Transducerized tool for Extreme Precision

- 4mm wing shank and half moon bits for the smallest screws
- Safety Critical Repeatability
- Traceability using internal transducer

Ergonomic Design

- Streamlined & contoured
- Non-slip Tool Housing
- Push / Lever start
- Highly Flexible Light Weight Industrial Cable
- M20 output thread for easy integration and automatization

Programmable Vacuum System Activation Options

- Built in Accelerometer
- Dedicated connector for 24V vacuum pump

PIC REF	MODEL	PART NUMBER	OUTPUT DRIVE	TORQUE				MAX SPEED	LENGTH		WEIGHT	
				MIN	MAX	MIN	MAX		rpm	mm	in.	kg
A	ERXS 20	615 165 874 0	WS-HM	6	20	0,53	1,77	1000	216	8,5	0,3	0,66
A	ERXS 50	615 165 875 0	WS-HM	15	50	1,32	4,43	1000	216	8,5	0,3	0,66
A	ERXS 80	615 165 876 0	WS-HM	24	80	2,12	7,08	1000	216	8,5	0,3	0,66

DESCRIPTION	PART NO.
TOOL & EXTENSION CABLE 3 METERS - 9,8 FT*	615 917 643 0

*Connect up to 3 cables (max 9 Meters - 29,5 ft)

Controller features

Power Supply

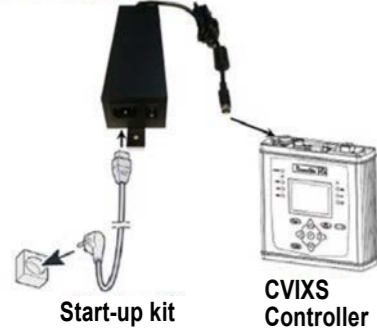

Start-up kit

PLUG	DESCRIPTION	PART NO.
A	European	615 917 201 0
B	US	615 917 203 0
C	UK	615 917 202 0
D	Chinese	615 917 206 0

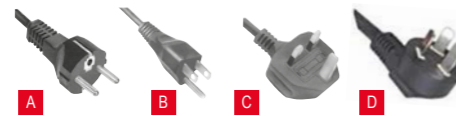

CVIXS supports

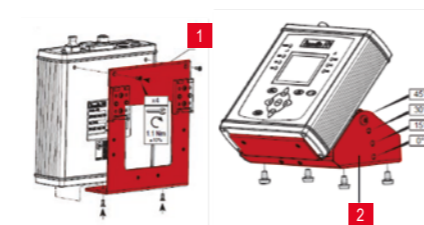

ITEM	DESCRIPTION	PART NO.
1	KIT RAIL DIN SUPPORT CVIXS	615 812 231 0
2	KIT ANGLE SUPPORT CVIXS	615 812 232 0

CVIXS fieldbus communication : order fieldbus module + fieldbus protocol

FIELD BUS PROTOCOL	MODEL	PART NO.	MODEL	PART NUMBER	TOOLS	CONSUMPTION (CURRENT)	SUPPLY VOLTAGE	DIMENSIONS						WEIGHT	
	1	2						3	4	5	6	7	8	9	10
	Fieldbus Module	615 932 721 0						mm	in.	mm	in.	mm	in.	kg	lb.
	Ethernet IP Module	615 929 051 0	CVIXS CONTROLLER	615 932 720 0	ERXS	150	36 VDC	171,6	6,73	171	6,75	54,6	2,15	1,12	2,2
	Profibus DP Module	615 929 052 0	CVIXS POWER SUPPLY	615 932 663 0	CVIXS	72-180	100-240 VAC	65	2,56	50	8,07	50	1,97	0,97	2,13
	ProfiNet Module (1 port)	615 929 053 0													
	ProfiNet Module (2 ports)	615 929 054 0													
	CC-Link Module	615 929 055 0													
	Devicenet Module	615 929 056 0													
	MODBUS TCP Slave	615 929 057 0													

ACCESSORIES

ITEM	DESCRIPTION	PART NUMBER
Vacuum solution		
1	"Blank nozzle short: 40mm. To be machined according to screw"	615 704 033 0
2	"Blank nozzle long: 60mm. To be machined according to screw"	615 704 034 0
3	"Vacuum adapter kit. For tool handheld. To be ordered with a blank nozzle"	615 812 883 0
Arms		
4	D53-5	615 810 700 0
5	D53-5S	615 810 706 0
6	Special clamp	615 812 885 5
Bits		
7	Refer to accessories catalogue	-
Miscellaneous		
8	Flange M20 for automatization	205 052 875 3
9	DTH42 Tool holster	107892



More Than Productivity



www.desouttertools.com

English
© Copyright 2017
April 2017 - Issue 1